



THE FUTURE IN OUR HANDS

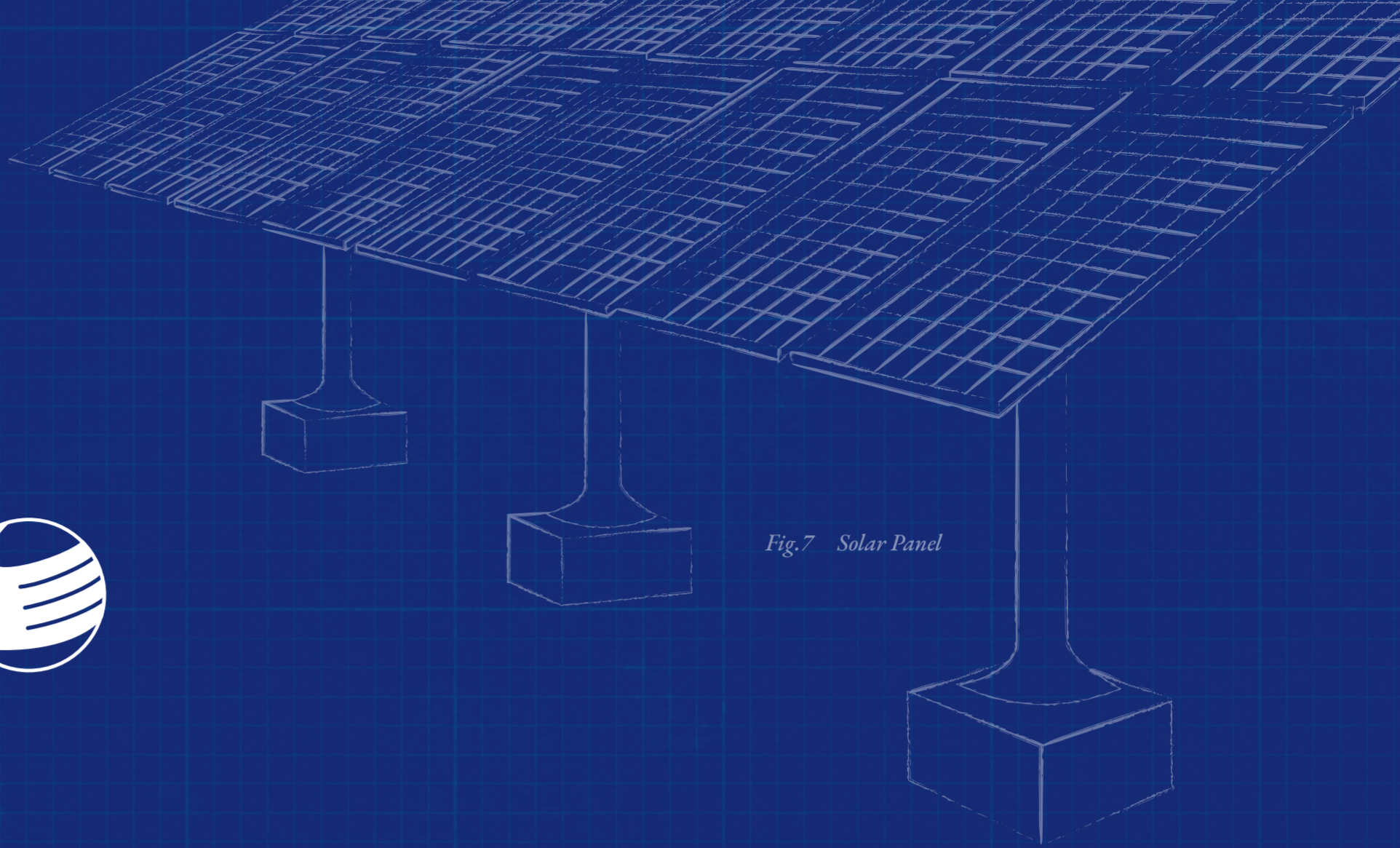

Fig.7 Solar Panel

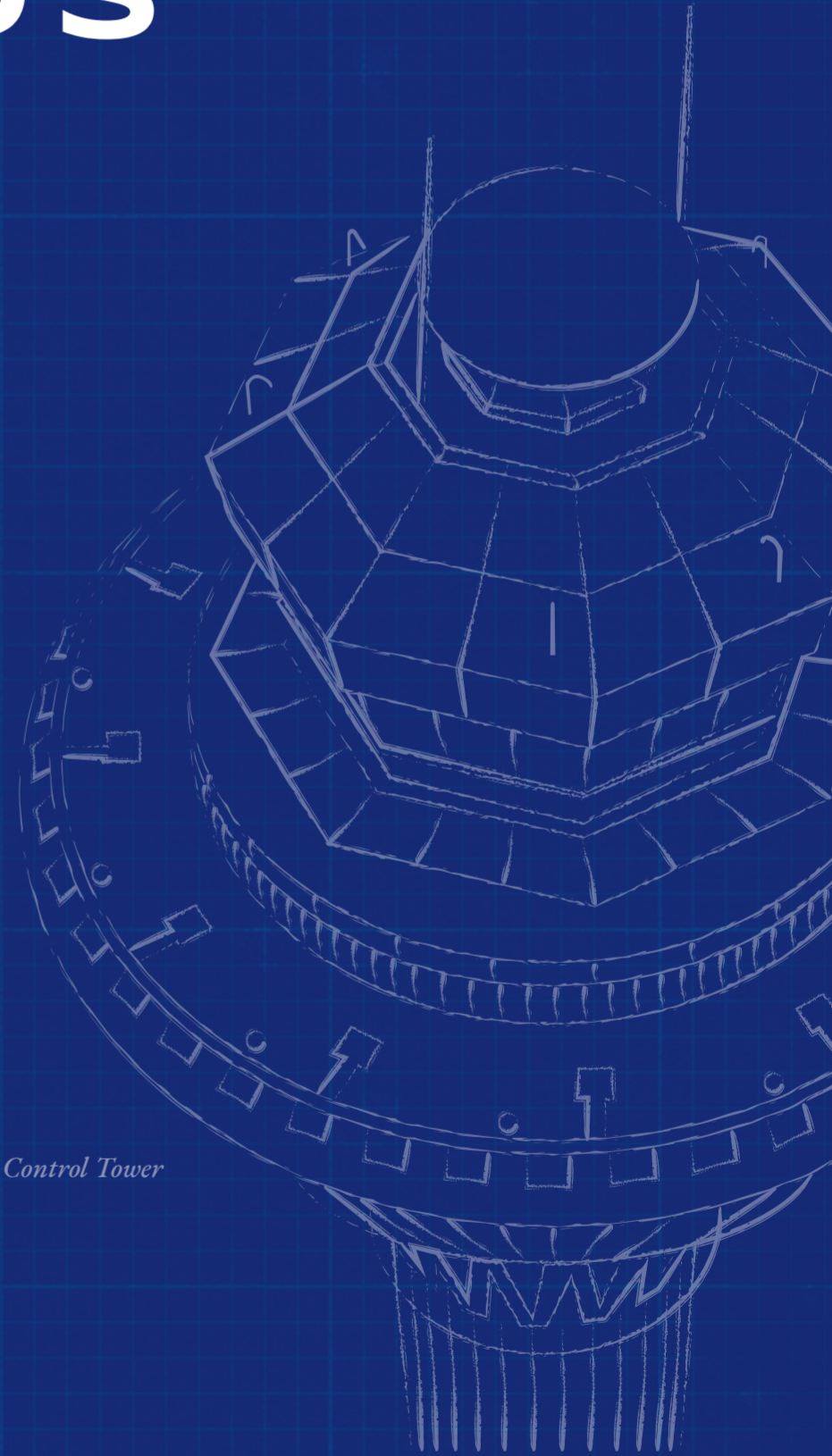

Fig.8 KLIA Air Traffic Control Tower

Fig.1 Mercu UEM, KL Sentral



We are UEM Group.

Our journey began in 1966.

UEM Group Berhad (UEM Group) is Malaysia's leading engineering-based and flagship infrastructure arm of Khazanah Nasional Berhad (Khazanah).

Our mandate is to lead Khazanah's domestic investment agenda in the infrastructure space as well as sustainable development initiatives in Malaysia.

Our presence transcends the borders of Malaysia into emerging and developed countries, focusing on these five key businesses:

Expressways & Airports



Connecting communities to shape a safe and sustainable future



Hosting joyful connection

Township & Property Development



Building communities of the future

Engineering & Construction



Transforming nation with care

Asset & Facility Management



Optimising assets to improve lives

Green Industries



For the future we live in

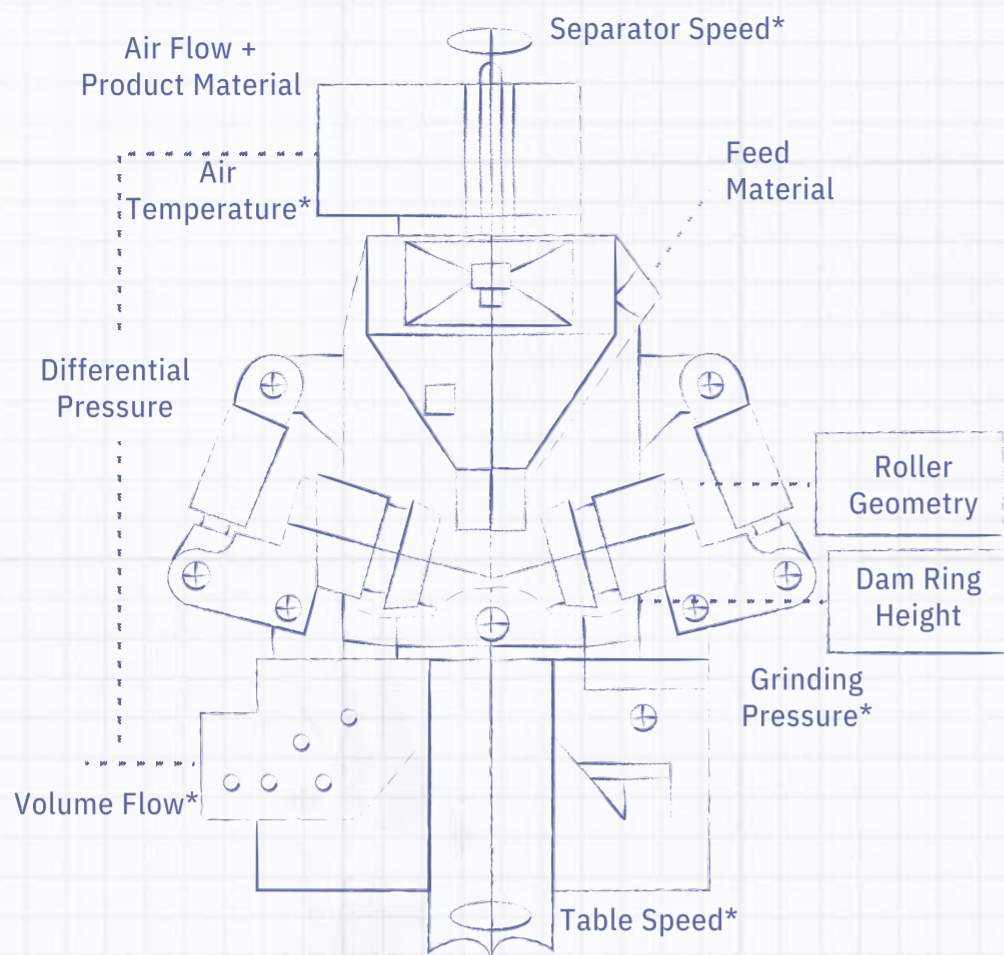

Fig.4 Cement Vertical Roller Mill

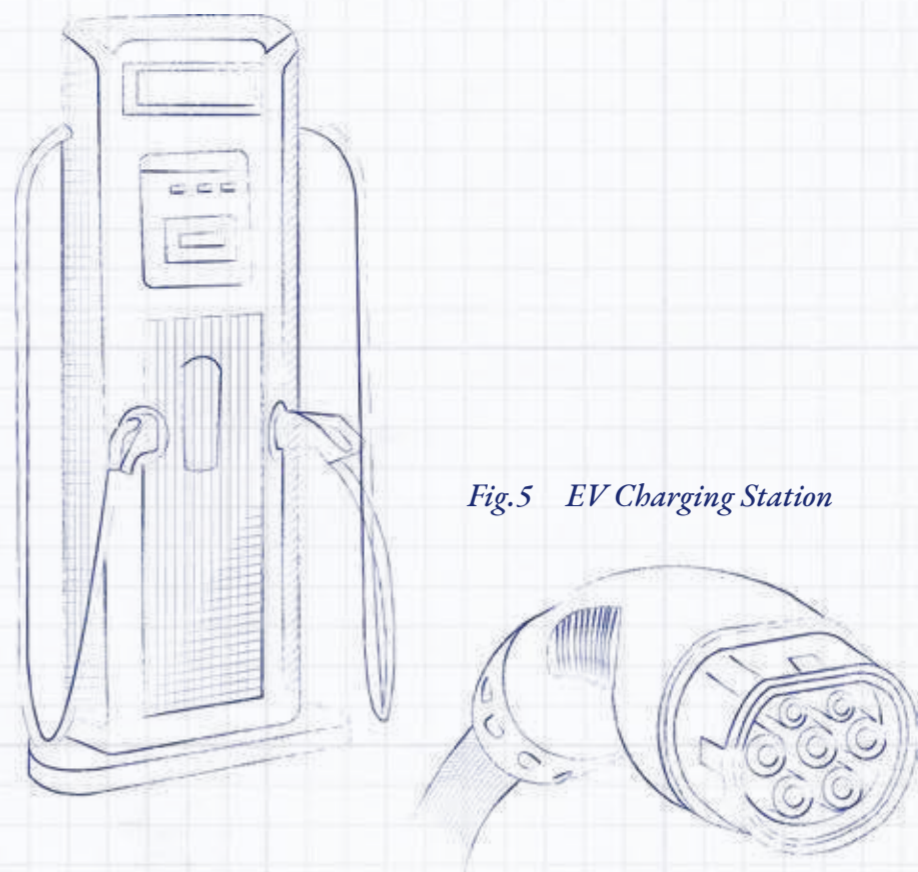

Fig.5 EV Charging Station

THE FUTURE IN OUR HANDS

As the flagship infrastructure arm and wholly-owned subsidiary of Khazanah Nasional Berhad, the sovereign wealth fund of Malaysia, our obligation goes beyond delivering financial numbers.

Our purpose is to safeguard and protect the interest of our nation and its people. In everything we do, we aim to leave significant positive and sustainable impact to everyone involved.

With an unwavering dedication and a steadfast spirit, we breathe life into aspirations, turning them into tangible realities. As architects of progress, we meticulously build the foundations of a future worth looking forward to.

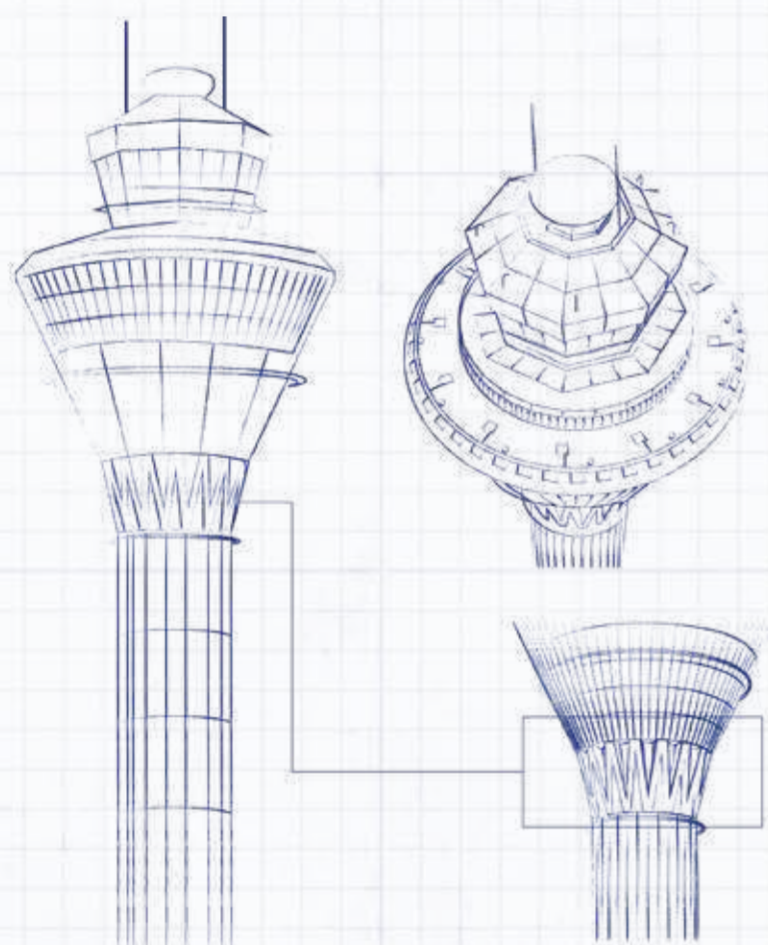

Fig.8 KLIA Air Traffic Control Tower

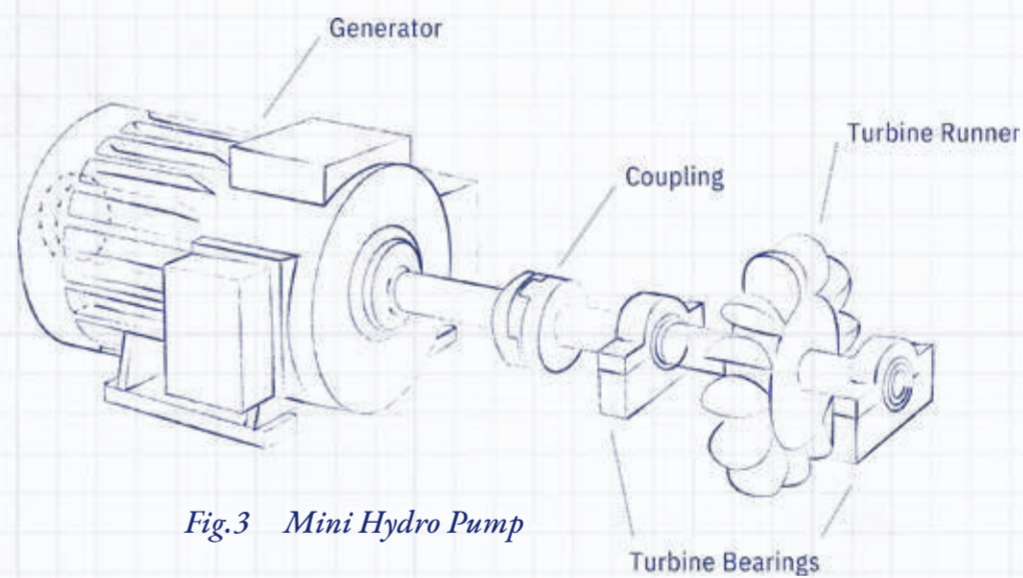

Fig.3 Mini Hydro Pump

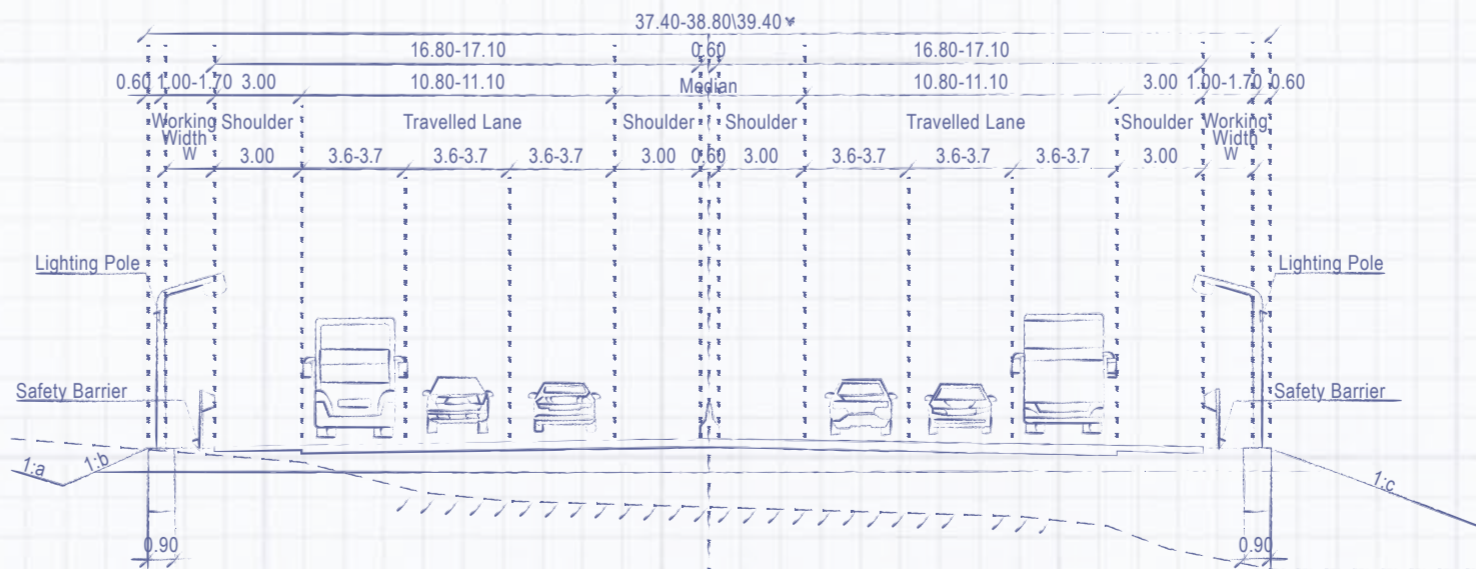

Fig.2 6-lane Expressway Cross Section



Fig.2 6-lane Expressway Cross Section

Connecting communities to shape a safe and sustainable future

Expressways & Airports



PLUS Malaysia Berhad (PLUS) is the expressway arm of UEM Group in Malaysia and has been operating the country's toll roads since 1988. It is the largest toll expressway operator in Malaysia and one of the largest in Southeast Asia.

PLUS operates and maintains almost 1,200 kilometres of expressways stretching from the border of Thailand in the North to the border of Singapore in the South as well as the East Coast.

These expressways connect major industrial, commercial and transportation centres, link major seaports and airports and provide easy access that has led to the developments of many townships and industrial centres.

Through PLUS Expressways International Berhad, UEM Group's expressways presence also extends to India and is represented by Uniquist Infra Ventures Private Limited.



Expressways & Airports



Hosting Joyful Connections

Malaysia Airports Holdings Berhad (MAHB) is one of the world's leading airport operator groups. Today, it manages 39 airports across Malaysia, comprising five international airports, 17 domestic airports and 17 STOLports (Short Take-Off and Landing airports), alongside Istanbul Sabiha Gökçen International Airport in Türkiye.

As a key UEM Group operating company, MAHB plays a strategic role in nation-building — enhancing connectivity, supporting tourism and trade and delivering safe, seamless travel experiences while advancing sustainability and innovation in airport operations.

Fig.8 KLIA Air Traffic Control Tower



Township & Property Development



UEM Sunrise Berhad (UEM Sunrise), a public-listed company and one of Malaysia's leading property developers, is the township and property development arm of UEM Group. It has core competencies in macro-township development, high-rise residential, commercial, retail and integrated developments.

UEM Sunrise is the master developer of Iskandar Puteri, Johor, envisioned to become Southeast Asia's largest fully integrated urban development.

It is also renowned as the pioneer developer of Gerbang Nusajaya, the largest township in Iskandar Puteri as well as award-winning townships and properties in Greater Kuala Lumpur.

UEM Sunrise has extended its mark internationally, notably, with a strong presence in Australia.



Fig.9 The MINH, Mont'Kiara. Luxury Residences

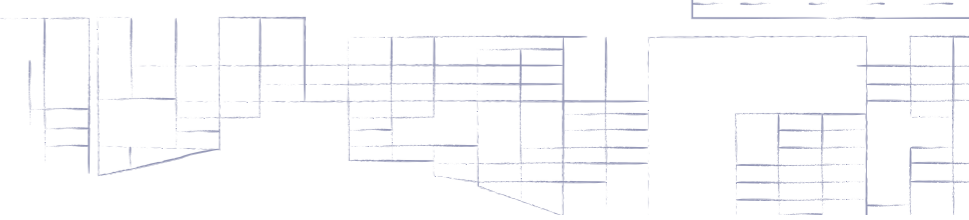
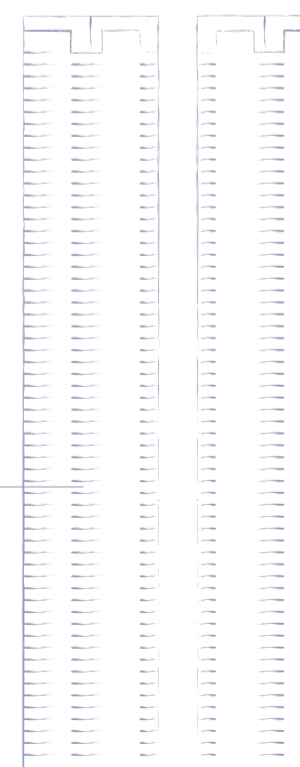
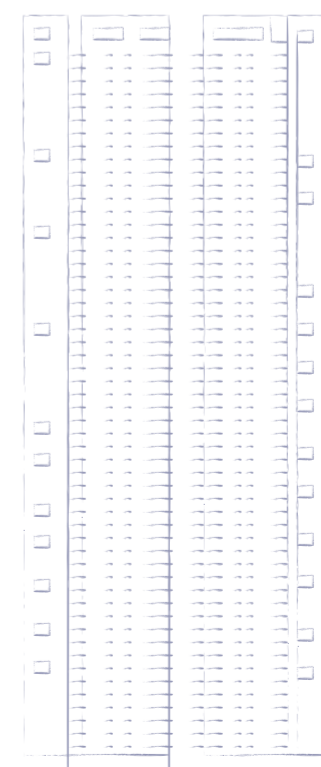

Engineering & Construction



Cement Industries of Malaysia Berhad (CIMA) is UEM Group's wholly-owned subsidiary and Malaysia's second largest cement producer in Malaysia with capacity to produce 7.2 million metric tonne of cement per annum.

Its products are exported to Singapore and are used in various iconic projects which have redefined Malaysia's infrastructure landscape, ranging from expressways, bridges, railroads and integrated developments.

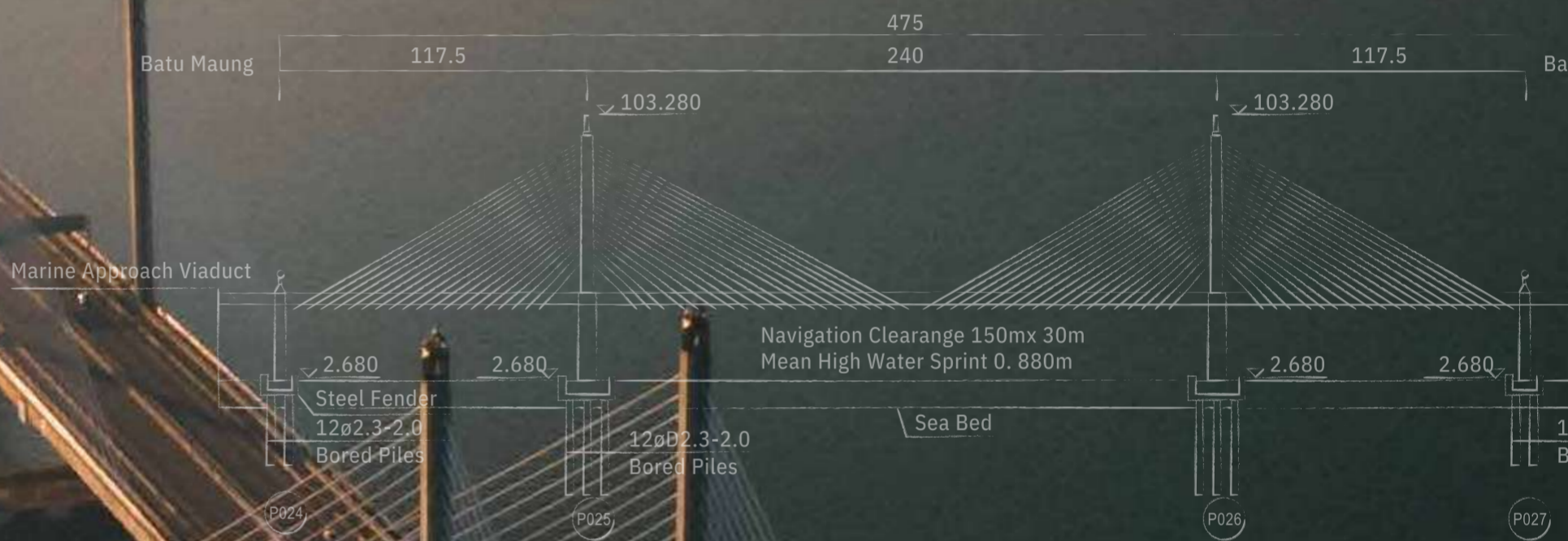

Fig.6 Sultan Abdul Halim Mu'adzam Shah Bridge, Penang



UEM Edgenta Berhad (UEM Edgenta) is the region's leading Asset Management & Infrastructure Solutions company. Listed on Bursa Malaysia, UEM Edgenta's expertise covers Healthcare Support and Property & Facility Solutions within its Asset Management segment and Infrastructure Services and Asset Consultancy within Infrastructure Solutions segment.

UEM Edgenta offers a full suite of services throughout an asset's life cycle, which includes consultancy, procurement and construction planning, operations and maintenance, as well as optimisation, rehabilitation and upgrades.

UEM Edgenta has an operational presence in Malaysia, Singapore, Indonesia, Taiwan, the United Arab Emirates and The Kingdom of Saudi Arabia.



UEM Edgenta Command & Contact Centre

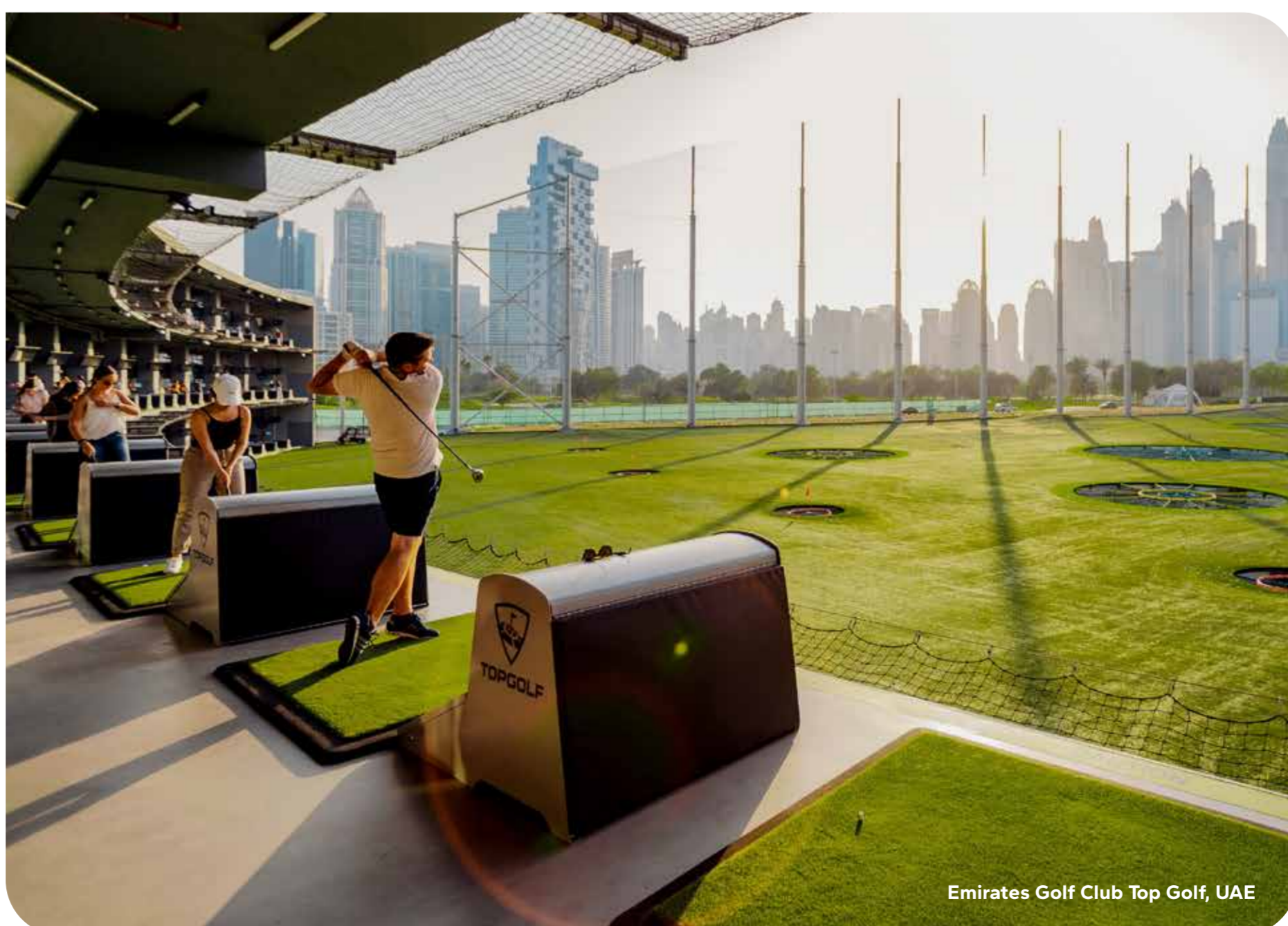

Emirates Golf Club Top Golf, UAE

Green Industries



Born from the Malay word, Lestari which means "sustainable", UEM Lestara Berhad (UEM Lestara) is the energy infrastructure arm of UEM Group.

UEM Lestara was created to support and develop Malaysia's green industries, infrastructure and ecosystem through investments in renewable energy spanning biogas, biomass, solar and small hydro power plants, electric vehicle charging infrastructure maintenance and services as well as decarbonisation ventures such as power utility plant and industrial parks.

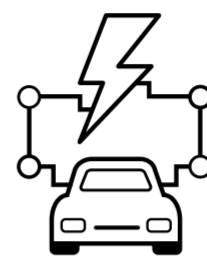

Green Electric Mobility



Circular Economy: Waste Management & Recycling

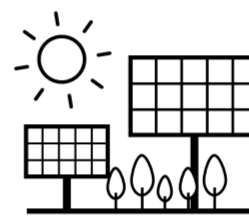

Renewables & Storage



Integrated Energy Solutions



Cenergi's Biogas Plant, Pulau Carey

UEM Lestra aims to play a role in realising Malaysia's low carbon ambitions through renewable energy and sustainability solutions.

Its key subsidiaries include **Cenergi SEA Berhad**, a company specialising in reducing carbon emissions through development of and investments in renewable energy projects specifically biogas, biomass, solar and small hydro power plants; **NUR Power**, Malaysia's first Independent Power Utility company that specialises in the generation, transmission, distribution and retail of electricity in the country and has been granted exclusive rights to provide electricity in Kulim Hi-Tech Park; and **Roda Emas Industries Sdn Bhd (REISB)**, a trusted name in Malaysia's electric vehicle infrastructure landscape.



NUR
power
a UEM LESTRA company



a UEM LESTRA company



RODA EMAS INDUSTRIES SDN BHD

a UEM LESTRA company

**For the future
we live in**



We aim to preserve and protect the environment, ensure our employees as well as our communities are nurtured and supported. We also aspire to make long-lasting and positive impact in the area of governance.

**Our steadfast
commitment
to ESG**



Environmental & Sustainability

SIREH Park – A Living Example of Environmental

We are of the opinion that progress should always go hand in hand with protecting our environment and biodiversity. We implement green initiatives to spark enthusiasm and raise awareness about our environment, as well as inspire our community to make eco-friendly choices.

SIREH Park by UEM Sunrise exemplifies our commitment. Spanning 343 acres in Iskandar Puteri, Johor, SIREH Park is a green lung developed through sustainable stewardship. From large-scale native tree planting to habitat restoration and eco-education, the Park promotes biodiversity, carbon sequestration and community engagement – showcasing UEM Group's dedication to long-term environmental resilience and responsible urban green space development.



Social - Community

Led by Yayasan UEM, the philanthropic arm of UEM Group, we lend a hand and strive to improve the lives of Malaysia's underprivileged communities. From medical assistance to humanitarian aid, distribution of provisions as well as implementing entrepreneurial development programmes (EDP).

In Langkawi for example, Yayasan UEM's sustainability-focused EDP initiative breathes new life into the island's coastal communities. We have teamed up with Centre for Marine and Coastal Studies (CEMACS) and created an engaging programme that benefit one's livelihood and the environment. Our first project focuses on new oyster farms. This venture not only revives sustainable aquaculture – cultivating tropical-hardy Pacific-Japanese oysters in mangrove-rich waters – but the locals are also equipped with hands-on training in farm operations, hatchery management and eco-tourism.

The result? A wave of social empowerment, fresh seafood offerings for visitors and viable livelihoods by the sea.



Social - Education

Investing in Talent Through Educational Equity

We believe education is a fundamental building block for individual opportunity and economic growth. We will continue to play our part in realising the country's aspiration of producing world-class human capital that will chart the future of Malaysia.

Our commitment to education is relentless and is translated into action through Yayasan UEM's various programmes such as our A-Level institution - Kolej Yayasan UEM (KYUEM), scholarships, study grants, tuition, numeracy and literacy programme, STEM classes and many more.



Governance

Strengthening Businesses the Right Way

At UEM Group, governance is more than compliance — it's a commitment to doing what's right. We prioritise ethics, trust, transparency and accountability across every level of our organisation. Our governance framework supports principled decision-making, active oversight and clear lines of responsibility.

With a strong stance against misconduct and full alignment with laws and regulations, we strive to build a business that's not only high-performing, but consistently honourable.

Changing the way we think and act today for a better tomorrow

UEM Group's history and legacy is intrinsically tied to the history and legacy of our proud nation. For close to 60 years, we have been a game changer, driving progress and creating opportunities for the nation to grow and prosper.

We are laying the foundation for the next future through a sense of hope, responsibility and belief that the future is ours to create - the future in our hands.

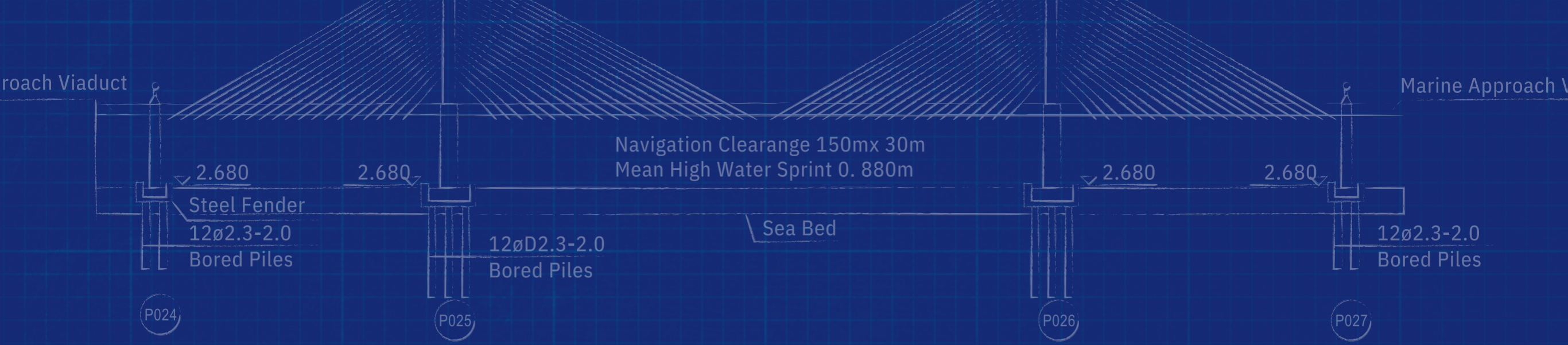

Fig.6 Sultan Abdul Halim Mu'adzam Shah Bridge, Penang

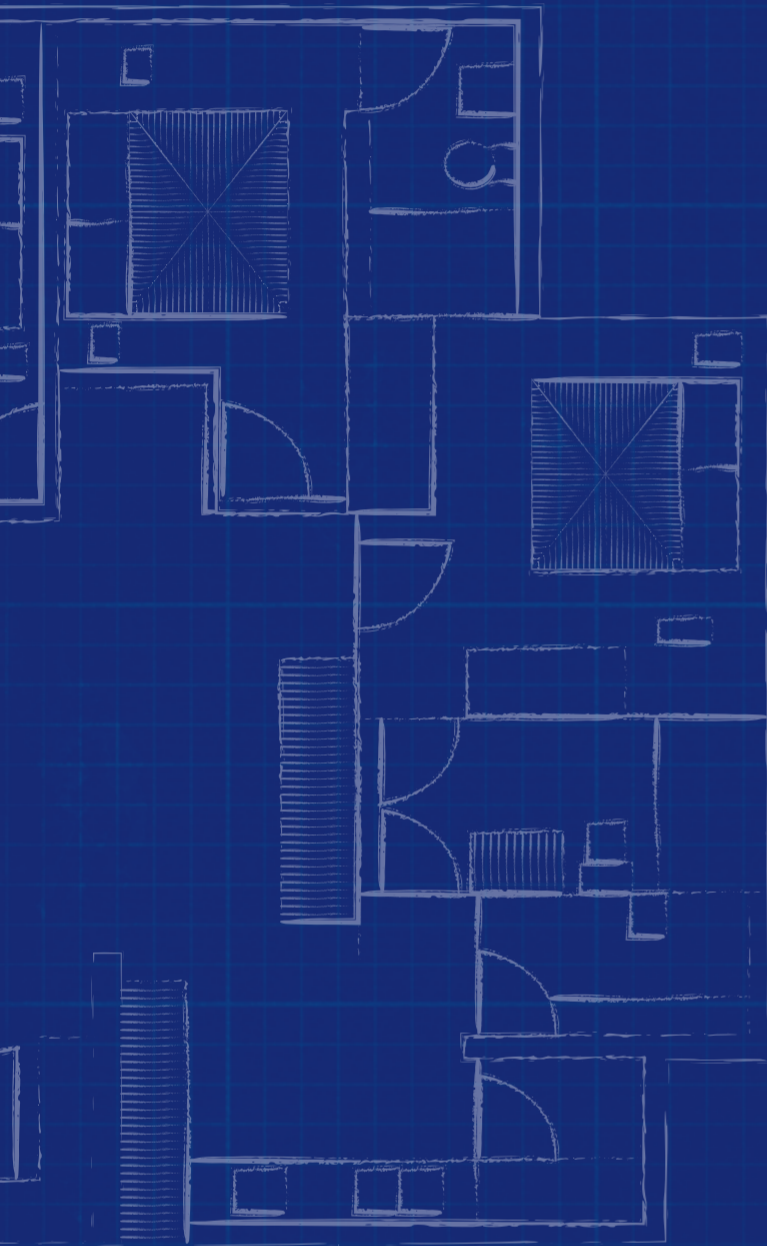

Fig.9 The MINH, Mont Kiara, Luxury Residences



UEM Group Berhad

19-2 Mercu UEM, Jalan Stesen Sentral 5
Kuala Lumpur Sentral, 50470 Kuala Lumpur
Wilayah Persekutuan

Tel: 03-2727 6868 Fax: +603 2727 2222
General Enquiries: uemcomms@uem.com.my

